

This drawing is the Property of GLEN DIMPLEX AUSTRALASIA LTD. All dimensions are outside/outside unless otherwise stated.

F7000 BRICK LAYOUT: 587844

PART NUMBER : 993901

REVISION LEVEL : A

| Amendment | Date | By |
|-----------|------|----|
| | | |
| | | |
| | | |

TOLERANCES :
 Decimal Places: 0 ± 0.5
 0.0 ± 0.2
 Angles Degrees: 0 ± 5°

| F7000 BRICK LAYOUT | | | |
|--------------------|---------|--------------------------------|----------|
| ITEM | PART ID | DESCRIPTION | QUANTITY |
| 1 | 587145 | BRICK-FIRE SIDE 25X160X250 | 4 |
| 2 | 587112 | BRICK-FIRE BACK LE 25X223X250 | 2 |
| 3 | 987146 | CHANNEL-BRICK RETAINER LE7 S/S | 3 |
| 4 | 993436 | BAFFLE-STEEL, WELDED F7000 | 1 |

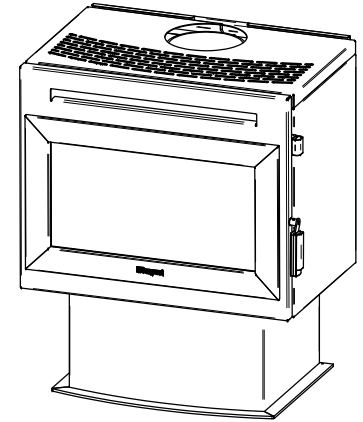
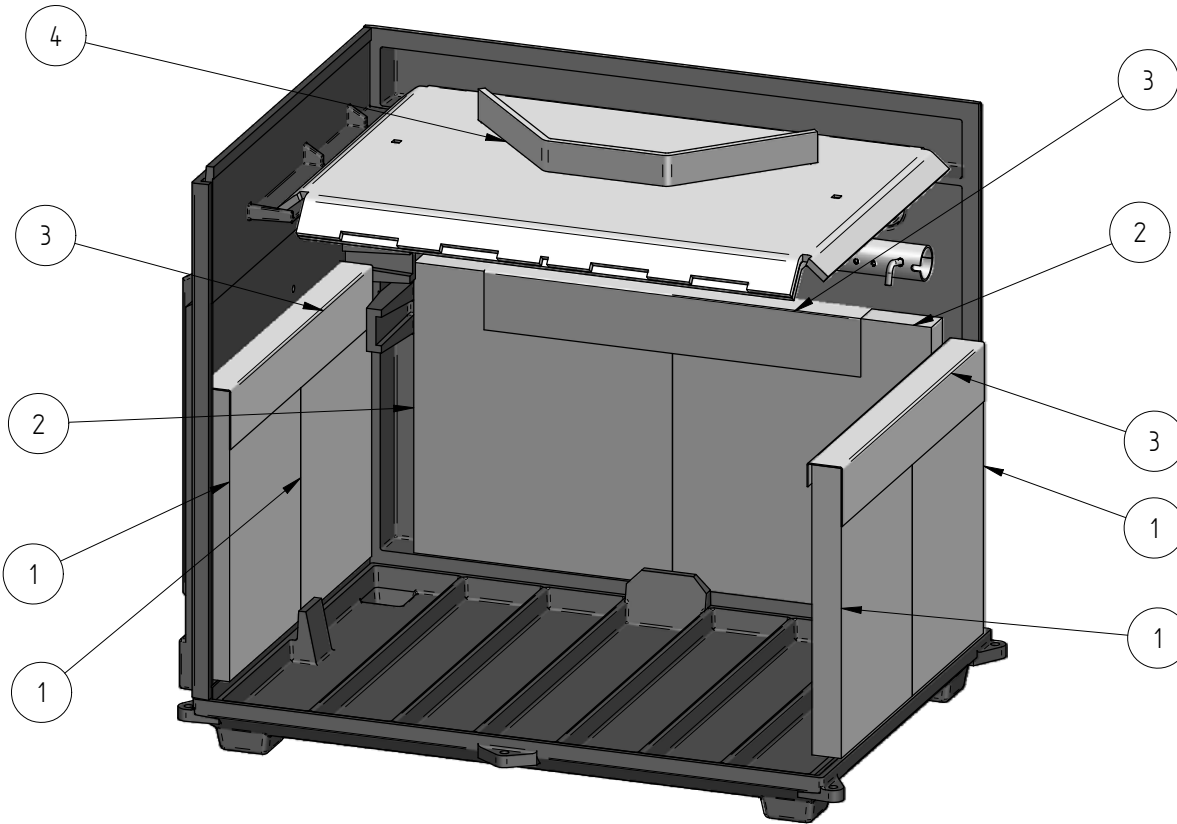

- NOTES FOR INSTALLING :**
- PLACE REAR BRICKS FIRST AS SHOWN IN FIREBOX.
 - FIT STAINLESS STEEL CHANNEL AS SHOWN OVER REAR BRICKS.
 - FIT L/H BRICK
 - FIT R/H BRICK
 - FIT STAINLESS STEEL CHANNEL AS SHOWN OVER L/H AND R/H BRICKS.

GLEN DIMPLEX AUSTRALASIA LTD
 38 HARRIS ROAD, EASTTAMAKI, AUCKLAND, NEW ZEALAND
 Ph 09 274 8265, Fax 09 274 8472, Email : eng_office@glendimplex.co.nz

| | | | | |
|---------------------------------|--------------|------------------|------------------|------------------|
| Customer : GDA | Drawing No : | Drawn : LK | Date : 09-Mar-09 | Chk'd By : |
| Part Name: F7000 FINAL ASSEMBLY | | Modified : Leonk | Date : 15-Jul-11 | |
| | | Material : | | Finish : Natural |